

PILOT DEVICE LEGEND

R1. HAND-OFF-AUTO SWITCH ILLUMINATED (GREEN)

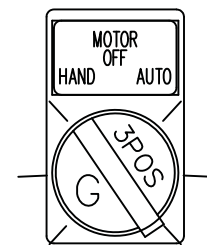

PILOT DEVICE LEGEND

R2. HAND-OFF-AUTO SWITCH ILLUMINATED (GREEN)

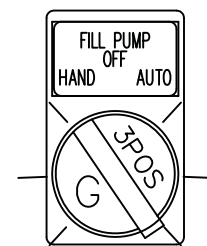

R3. FUEL OVER FILL ILLUMINATED (RED)

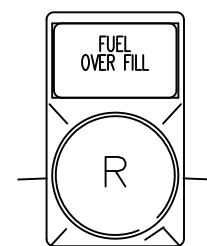

BACK OF CABINET

NOTES: CONTROLLER MAIN POWER SWITCH IS NOT SERVICE RATED, MUST SUPPLY A SERVICE RATED DISCONNECTING MEANS IF CONNECTED TO SERVICE POWER.

ALL DIMENSIONS ARE SHOWN IN INCHES AND CENTIMETERS ([]).

FUEL TRANSFER PANEL OUTLINE

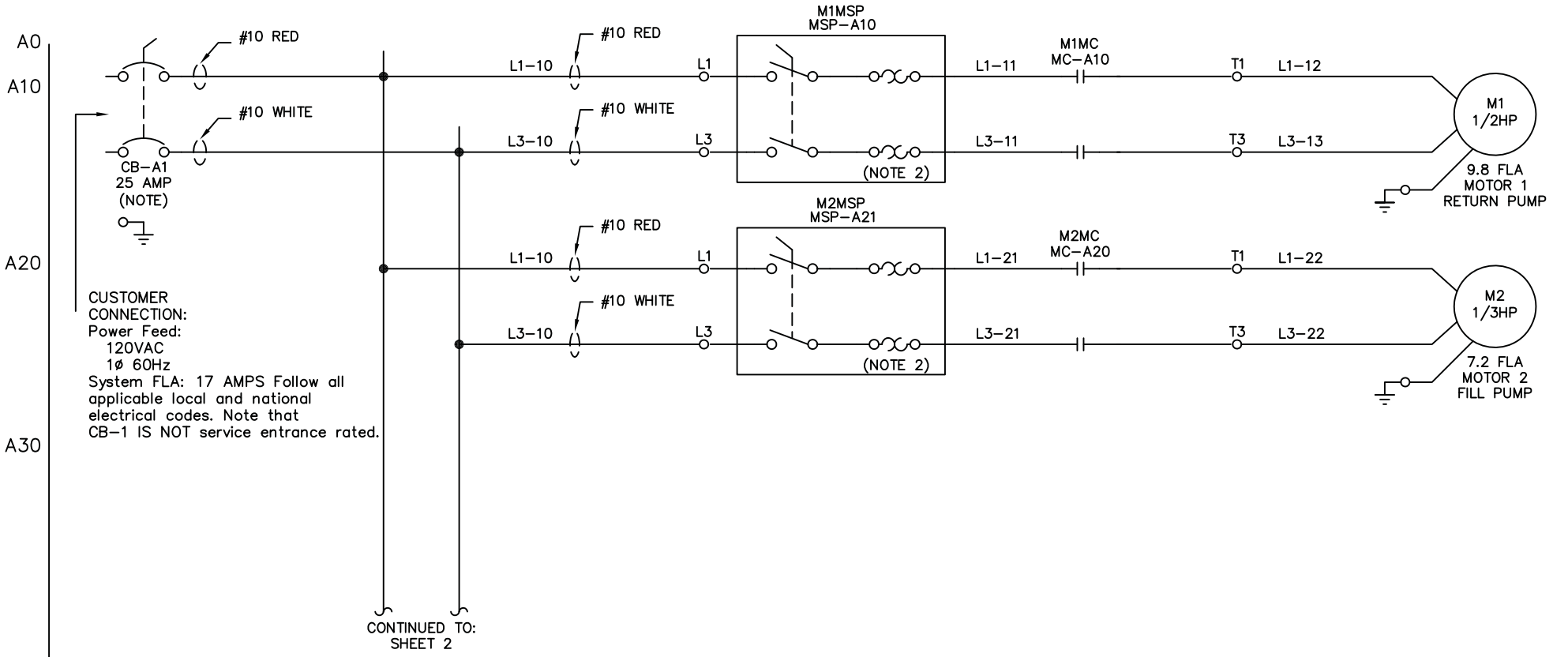

CUSTOMER CONNECTION:
 Power Feed:
 120VAC
 1Ø 60Hz
 System FLA: 17 AMPS Follow all applicable local and national electrical codes. Note that CB-1 IS NOT service entrance rated.

CONTINUED TO:
 SHEET 2

(NOTE 1) - TO REDUCE THE RISK OF FIRE, REPLACE ONLY WITH
 - SAME TYPE AND RATING OF FUSE AS ORIGINALLY INSTALLED OR EQUAL.

(NOTE 2) - SET OVERLOAD RELAY SETTING TO THE NAMEPLATE AMPS
 - OF THE RESPECTIVE MOTOR.

FUEL TRANSFER PANEL
 SCHEMATIC

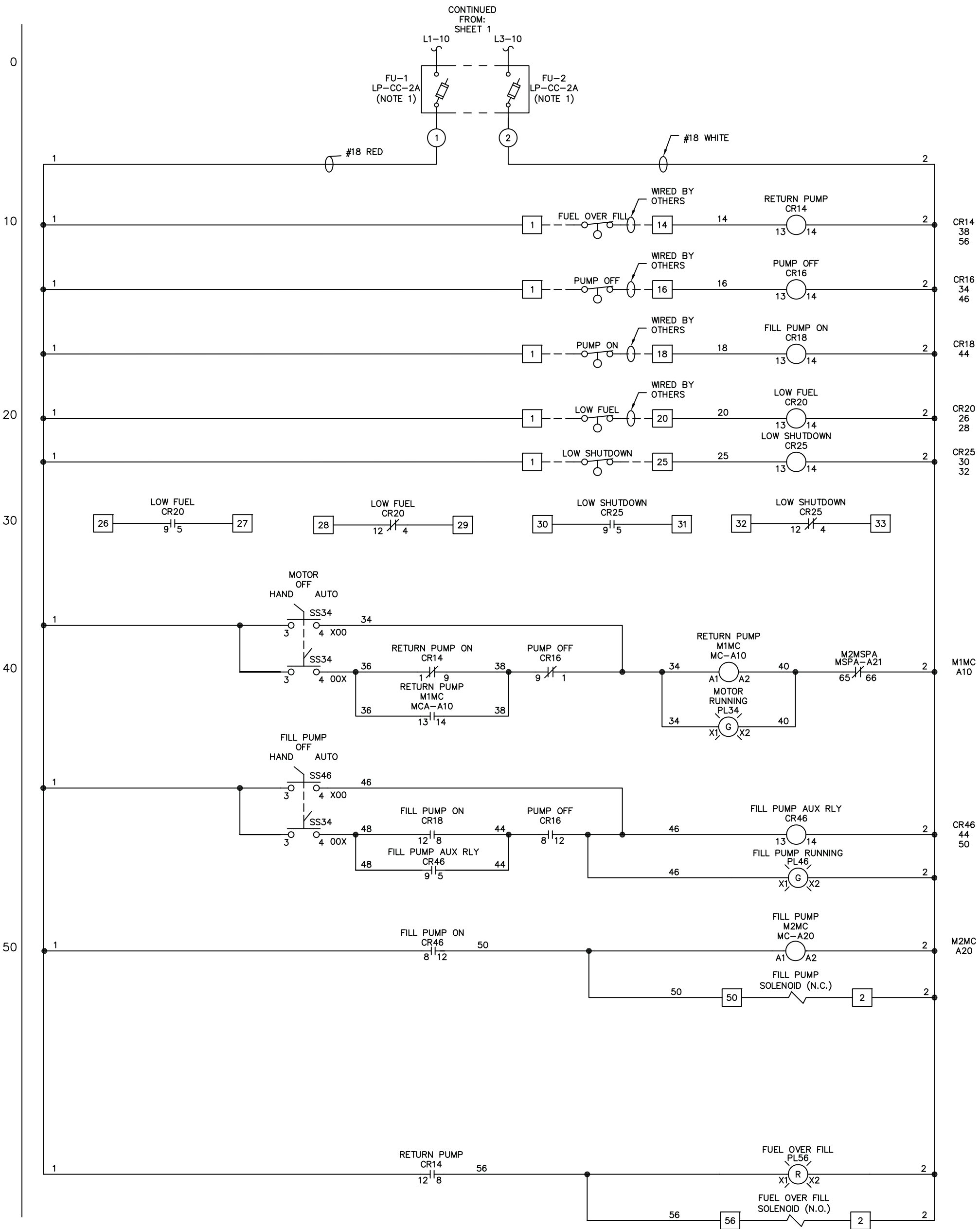

(NOTE 1) - TO REDUCE THE RISK OF FIRE, REPLACE ONLY WITH
 - SAME TYPE AND RATING OF FUSE AS ORIGINALLY INSTALLED OR EQUAL.

(NOTE 2) - SET OVERLOAD RELAY SETTING TO THE NAMEPLATE AMPS
 - OF THE RESPECTIVE MOTOR.

FUEL TRANSFER PANEL SCHEMATIC

